

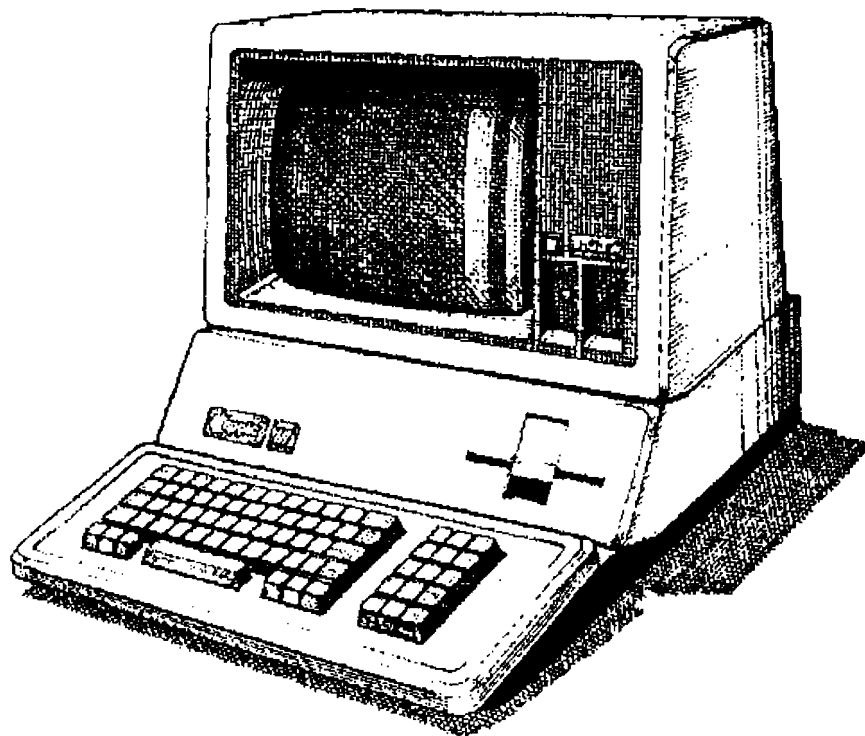

Apple /// Computer Information

# Apple /// Service Reference Manual



Section I of II • Theory of Operation

Chapter 6 • Video Display Logic

Written by Apple Computer • 1982



## DISPLAY MODES

- o 40 CHARACTER APPLE II : 40x24 CHARACTER B/W TEXT (2K BYTES RAM)
- o 40 CHARACTER APPLE ///: 40x24 CHARACTER COLOR TEXT - 16 BACKGROUND, 16 TEXT COLORS
- o 80 CHARACTER BLACK & WHITE APPLE ///: 80x24 CHARACTER B/W TEXT
- o BLACK & WHITE HIRES: 280x192 B/W HIRES (8K RAM)
- o MEDIUM RESOLUTION 16 COLOR GRAPHICS APPLE ///: 280x192 16 COLOR HIRES WITH 40x192 BACKGROUND/ FOREGROUND RESOLUTION
- o SUPER HIRES APPLE ///: 560x192 B/W HIRES
- o APPLE /// HIRES: 140x192 16-COLOR HIRES
- o RAM CHARACTER GENERATOR (128 CHARACTER)



## APPLE /// VIDEO

### INTRODUCTION

The Apple /// has 11 defined video modes of operation. There are 5 Apple ][ modes and 6 new Apple /// modes. There are now 3 text modes and 8 graphics modes. Though the Apple /// can emulate all of the Apple ][ video modes, there are many differences in the video hardware between the Apple ][ and Apple ///, including:

- o 80 column text with full upper and lower case character capability
- o New color text mode
- o Super high resolution black and white graphics
- o 2 new color hires modes

#### AND

- o A modifiable character set

The modifiable character set is a major new feature of the Apple ///. You can now change the character set by changing the pattern in the character generator. This is possible because of a ram, instead of a fixed rom configuration.

There are also improved video outputs. An NTSC (National Television Standards Committee) composite Black and White and color composite, plus the primary video signals, are available at the back panel for mixing into the input of a high quality RBG monitor.

The Apple ][ emulation mode has the very same video modes as the Apple ][. The Apple ///, while in its native mode, can have the following modes.

### 40 Character Apple ][

This mode is equivalent to the Apple ][ text mode. The only difference is it has upper and lower characters.

- o The screen is divided into 40 horizontal columns and 24 vertical lines.
- o The characters are usually white dots on a black background.
- o This mode has inverse video and flashing characteristics.
- o This mode has no color.



- o This mode has two screen pages mapped into memory:
  - Page 1 is located at 0400-07FF
  - Page 2 is located at 0800-0BFF.

#### 40 Character Apple ///

This second 40 character text mode is the most interesting and, in a way, the most powerful. This is the only color text mode. It has the same screen resolution as the Apple ][, and the same video attributes. BUT it also has the ability to select both the color of the foreground (dots) and the color of the background. Sixteen (16) colors are available as in the Apple ][ Lores Graphics.

- o The color resolution can be selected for each character and can change for each character.
- o It is interesting to note that by down loading a character set, a new low resolution graphics mode can be manufactured from a text mode.

The page mode is different for this mode since both pages are used at once. Why? Because the first page contains the character data and the second page contains the color information. The page 2 mode reverses the mapping, that is, the characters in page 2 are stored where the color was stored in page 1, and vice versa.

In the color byte, bits 4-7 set the foreground color and bits 0-3 set the background color. The mapping between color and character is 1:1. That is, a character located in 0409, for example, has its foreground color determined by the byte in location 0809.

In the page 1 mode the mapping is as follows:

- 0400-07FF contain the characters
- 0800-0BFF contain the color information.

In the page 2 mode:

- 0800-0BFF contain the characters.
- 0400-07FF contains the color.

#### 80 Character Black & White Apple ///

This new text mode is the same as the 40 column mode with the obvious exception that it has 80 columns instead of 40. This 80 column display has full upper and lower case, and inverse video.

Unlike the 40 character mode, it does not have 2 distinct pages. It uses both



pages to hold the characters.

The memory mapping for Page 1 utilizes:

0400-07FF for the primary fetch

0800-0BFF for the secondary.

In this mode, location 0400 contains the first character and 0800 contains the second. The third and the fourth characters come from locations 0401 and 0801 respectively.

In the Page 2 mode the primary fetch is from 0800-0BFF and the secondary from 0400-07FF. Therefore, the first and third characters come from 0800 and 0801 and the second and fourth come from 0400 and 0401.

Black & White Hires

This is a new graphics mode that has a 280 by 192 resolution in Black and White only.

It has two distinct pages:

Page 1 is located at 2000-3FFF

Page 2 is located at 4000-5FFF.

Medium Resolution 16 Color Graphics Apple ///

This is a new graphics mode for the Apple ///. It has the same dot resolution as the Apple ][ Hires (280 by 192), but it has an expanded color capability of 16 background colors. The B/W Output will yield 16 levels of grey scale.

The screen is divided into a 40 wide by 192 high matrix. That is, the color selection for foreground and 16 background can change for each 7 dot [ooooooo] pixel segment. You can think of each segment as a one-bit-high slice across a character space, as illustrated below.

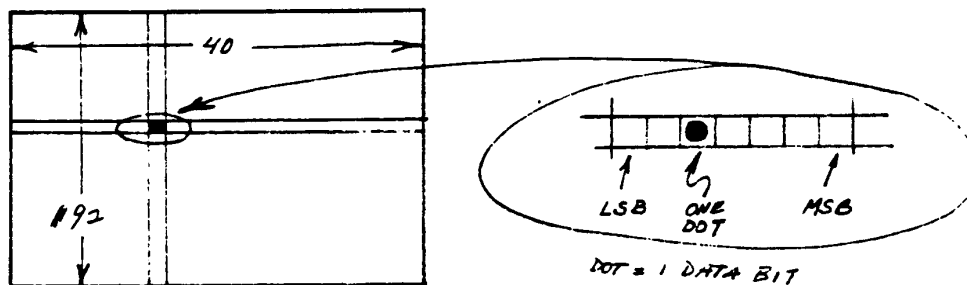

6.4



The memory mapping is as follows:

Page 1: 2000-3FFF each byte represents 7 pixels in the segment  
4000-5FFF each byte represents the foreground and background colors  
for the corresponding 2000-3FFF byte.

Page 2: 2000-3FFF each byte represents the colors  
4000-5FFF each byte represents 7 pixels.

### Super Hires Apple ///

This is the Apple /// Hires equivalent of 80 character mode. It is a Black and White mode which has the dot resolution of 560 Horizontal by 192 vertical spaces.

There are two distinct screen pages, each with a primary and secondary page. Because it is like the 80 character modes, this mode draws its information from alternating ram. Each memory byte contributes 7 pixels. In Page 1 mode, the primary contains the odd dot groups and the secondary contains the even dot groups. The primary (first 7 pixels) is located at 2000-3FFF, and the secondary (second 7 pixels) is found at 4000-5FFF. In Page 2 the primary is at 6000-7FFF, and the secondary is 8000-9FFF.

In each byte the Most Significant Bit (MSB) is ignored and the data is displayed with the Least Significant Bit (LSB) first from left to right.

### Apple /// Hires

This is the third new graphics mode. It has 140 by 192 pixel resolution, and 1 of 16 color selection per pixel. In this mode the pixel is formed by a group of four dots of the same color.

There are two distinct screen pages in this mode but the mapping of the individual pages is, at first encounter, a bit difficult to master. Good luck!

- o The display dot represents a sequence of 4 data bits in the RAM display area.
- o Two rams are used starting at 2000 and 4000 respectively and alternate bytes are fetched from each ram area.



- o In any video mode only 7 of the 8 bits of each byte are displayed.

With this information in mind...and remembering that each pixel in this mode is made from 4 bits...you can see that you need 4 bytes of information to get 7 pixels. The way in which these bytes map into picture elements is shown below.

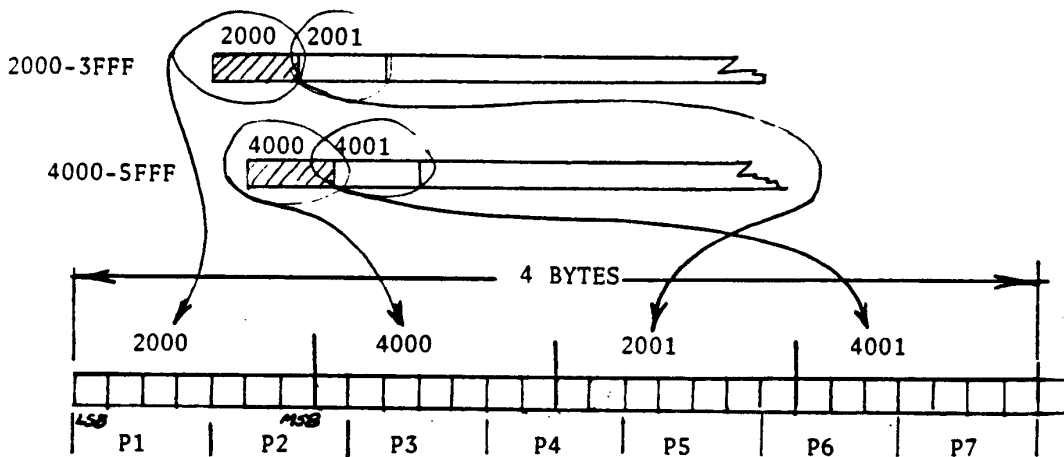



4000-5FFF each byte represents 7 pixels.

### Super Hires Apple ///

This is the Apple /// Hires equivalent of 80 character mode. It is a Black and White mode which has the dot resolution of 560 Horizontal by 192 vertical spaces.

There are two distinct screen pages, each with a primary and secondary page. Because it is like the 80 character modes, this mode draws its information from alternating ram. Each memory byte contributes 7 pixels. In Page 1 mode, the primary contains the odd dot groups and the secondary contains the even dot groups. The primary (first 7 pixels) is located at 2000-3FFF, and the secondary (second 7 pixels) is found at 4000-5FFF. In Page 2 the primary is at 6000-7FFF, and the secondary is 8000-9FFF.

In each byte the Most Significant Bit (MSB) is ignored and the data is displayed with the Least Significant Bit (LSB) first from left to right.

### Apple /// Hires

This is the third new graphics mode. It has 140 by 192 pixel resolution, and 1 of 16 color selection per pixel. In this mode the pixel is formed by a group of four dots of the same color.

There are two distinct screen pages in this mode but the mapping of the individual pages is, at first encounter, a bit difficult to master. Good luck!

- o The display dot represents a sequence of 4 data bits in the ram display area.
- o Two rams are used starting at 2000 and 4000 respectively and alternate bytes are fetched from each ram area.
- o In any video mode only 7 of the 8 bits of each byte are displayed.

With this information in mind...and remembering that each pixel in this mode is made from 4 bits...you can see that you need 4 bytes of information to get 7 pixels. The way in which these bytes map into picture elements is shown below.





It is apparent, from the diagram, that picture elements overlap the byte boundaries for 7 picture elements and 4 bytes. The basic pattern then repeats.

The four bytes are shifted out in a fashion similar to the other Apple /// modes:

- o The first byte comes from the primary and the second byte comes from the secondary.
- o The first byte contains the first pixel and the second byte comes from the secondary.
- o The first byte contains the first pixel and 3 bits of the second pixel.
- o The second byte contains the fourth bit of the second pixel, the third pixel, and the first two bits of the fourth pixel.
- o The third byte contains the last two bits of the fourth pixel, the fifth pixel, and the first bit of the sixth pixel.
- o The fourth byte contains the last three bits of the sixth pixel and the entire seventh pixel.

We hope the preceding diagram will help you picture what has already been described.

For this mode, Page 1 is mapped with the primary fetch in 2000-3FFF, and the secondary in 4000-5FFF. In Page 2 the primary is in 6000-7FFF, and the secondary is in 8000-7FFF.



APPENDIX (VIDEO)

- o Apple /// Video Logic Block Diagram
- o Video Logic Diagrams for:
  1. Hires Mode Page 1, B/W 280 X 192
  2. Hires Mode Page 2, B/W 280 X 192
  3. Color Hires Mode Page 1, 280 X 192
  4. Color Hires Mode Page 2, 280 X 192
  5. Super Hires Mode Page 1, 560 X 192
  6. Super Hires Mode Page 2, 560 X 192
  7. Ahires Test Page 1, 140 X 192
  8. Ahires Test Page 2, 140 X 192
  9. Color Bar & Grey Scale Test
  10. Apple II Text Mode Page 1, B & W, 40 Column
  11. Apple II Text Mode Page 2, B & W, 40 Column
  12. Sara 40 Column Text Mode Test, 16 Colors
  13. Sara 80 Column Text Mode Test, B & W
- o Apple /// Video Modes Truth Tables
- o Video Prom Listing
- o Video Prom Equivalent Logic

APPLE III VIDEO LOGIC BLOCK DIAGRAM

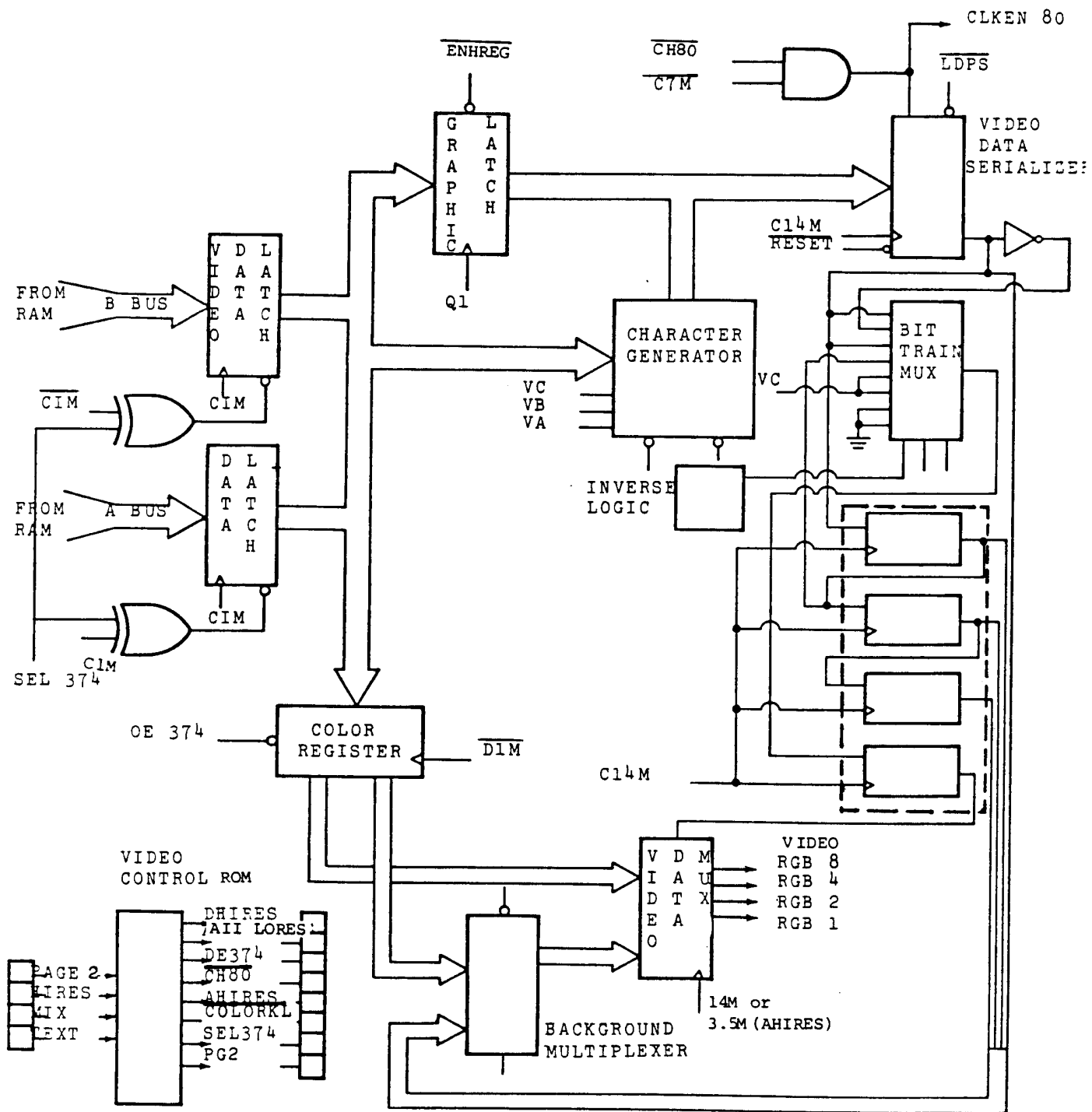

6.10

A/// VIDEO LOGIC DIAGRAM

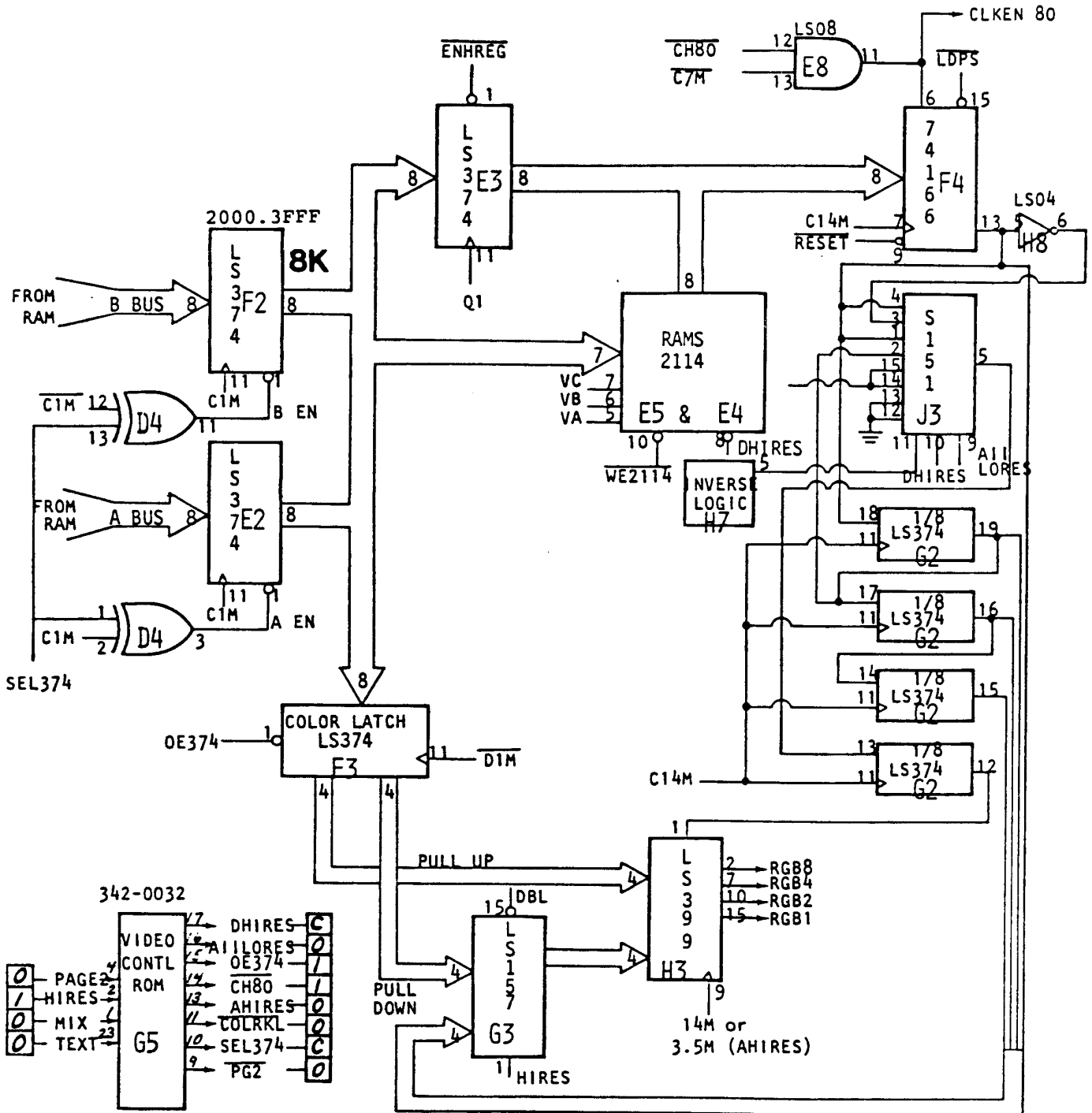

1. HIRES MODE PAGE 1 - B & W - 280 X 192  
2000.3FFF (8K)

A/// VIDEO LOGIC DIAGRAM

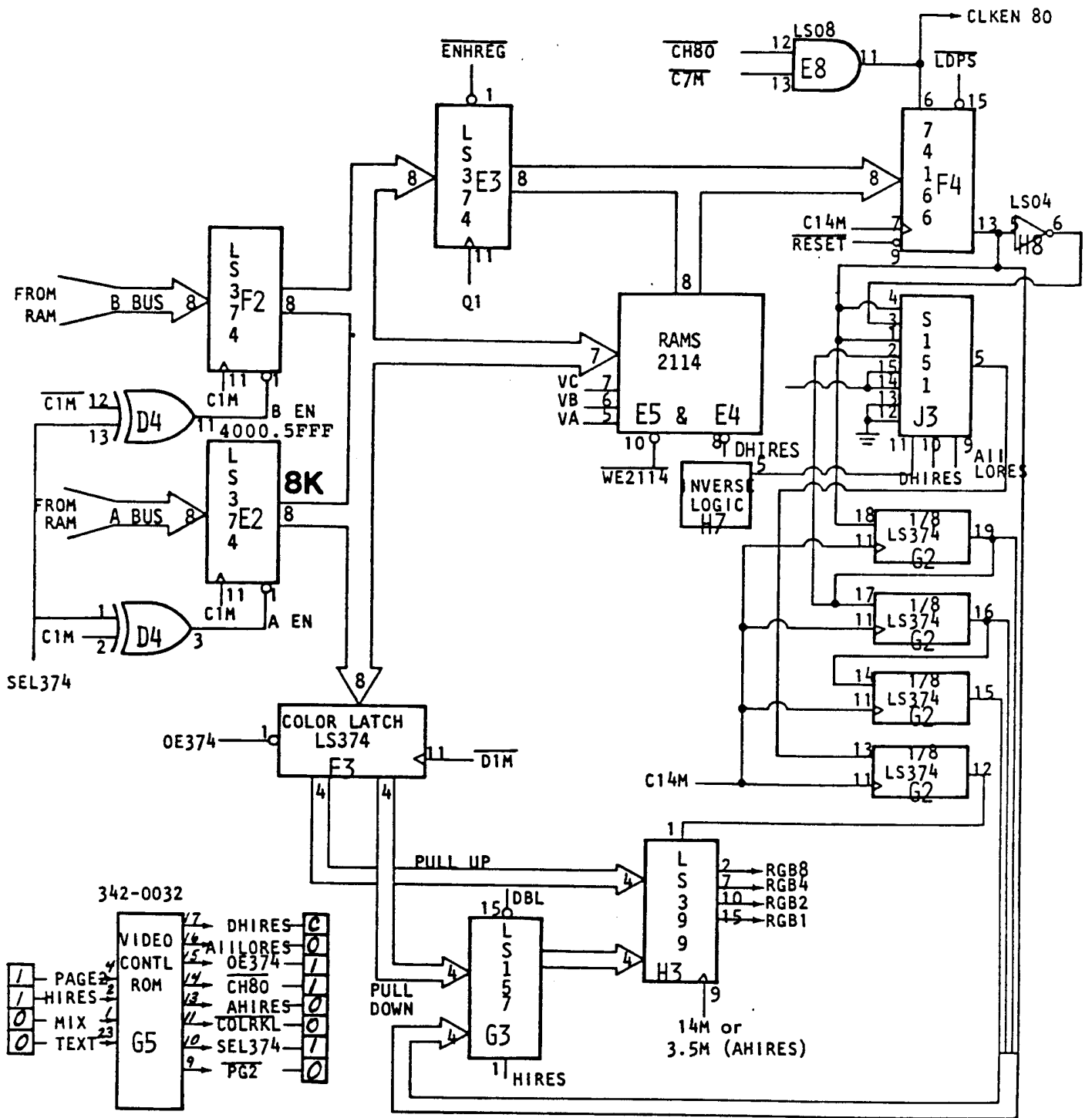

2. HIRES MODE PAGE 2 - B & W - 280 X 192  
4000.5FFF (8K)

A/// VIDEO LOGIC DIAGRAM

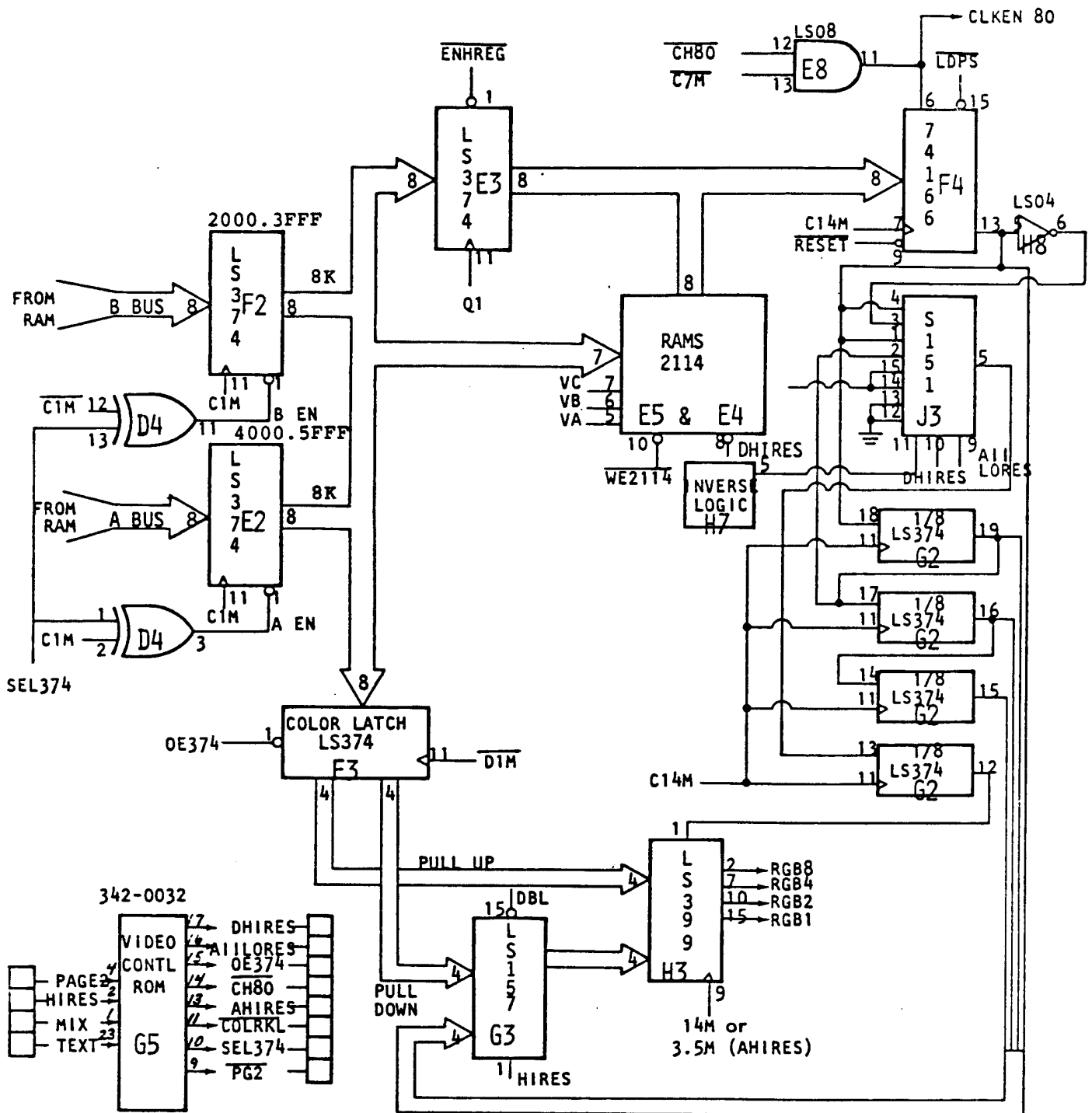

3. 280 X 192 COLOR HIRES MODE PAGE 1 ( FGD/BKGD HIRES)  
2000.5FFF (16K)

A/// VIDEO LOGIC DIAGRAM

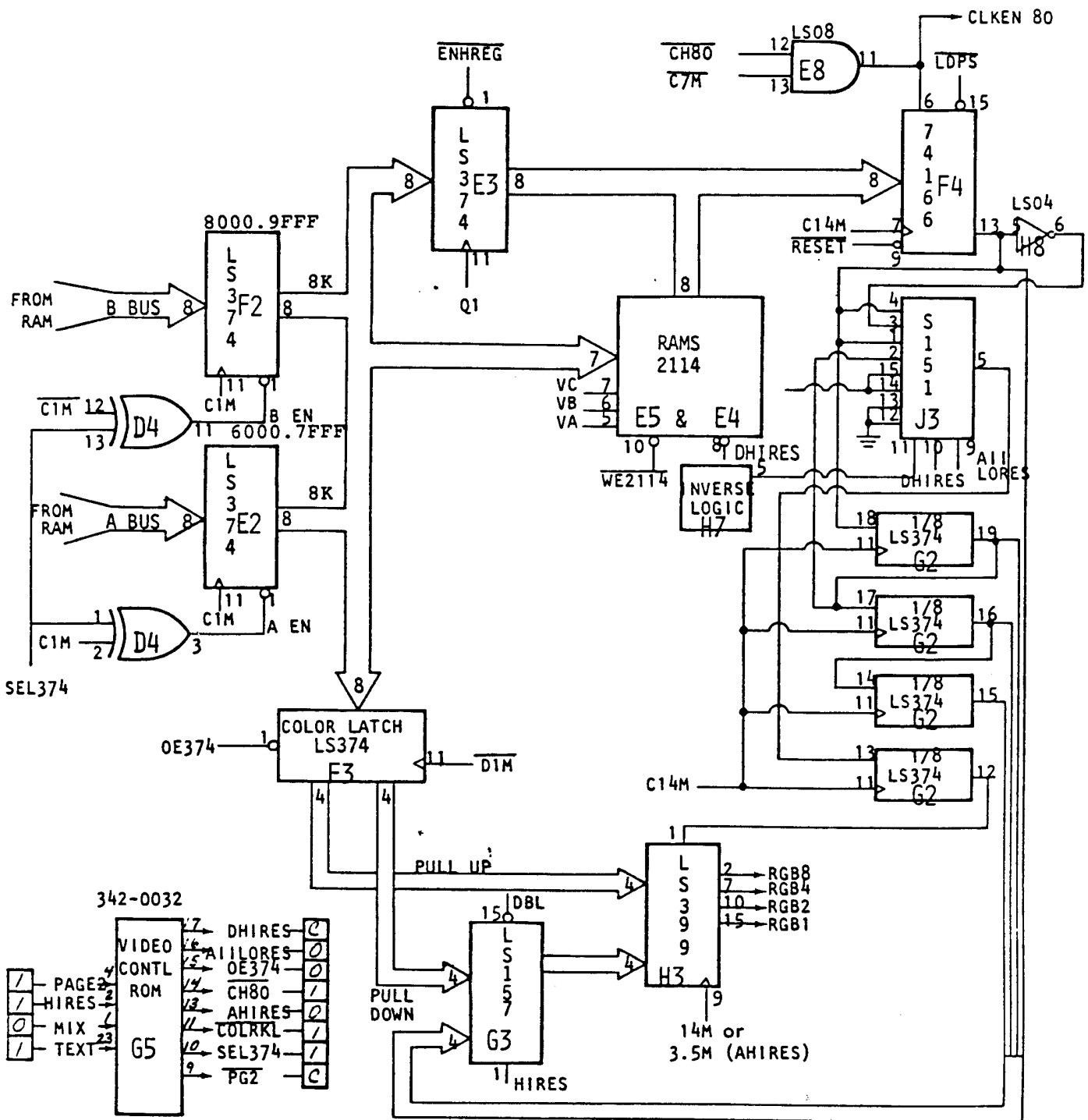

4. 280 X 192 COLOR HIRES MODE PAGE 2 (FGB/BKGD HIRES)  
6000.9FFF (16K)

6.14

### A/// VIDEO LOGIC DIAGRAM

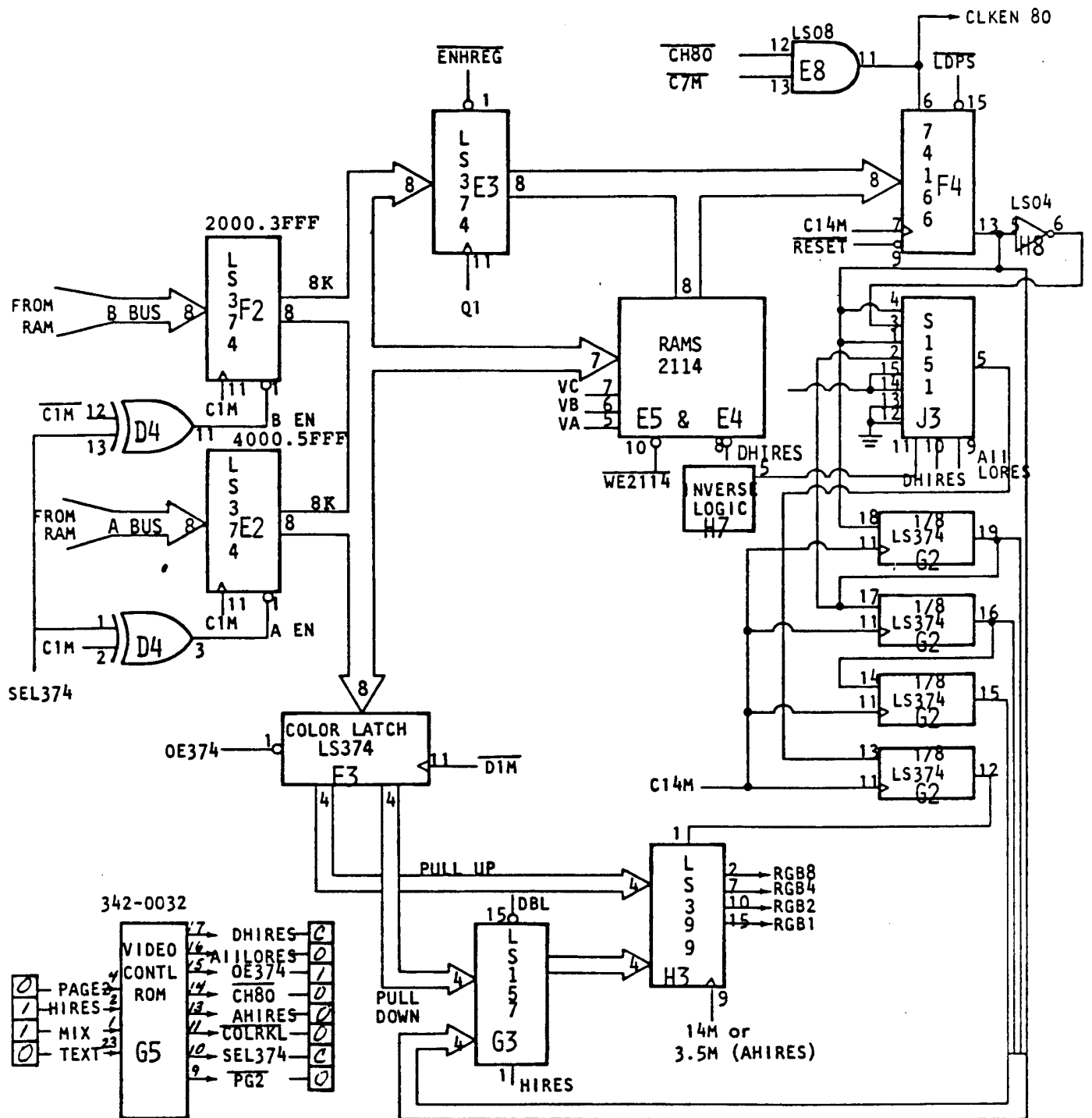

5. SUPER HIRES MODE PAGE 1 - B & W - 560x192  
2000.5FFF (16K)



A/// VIDEO LOGIC DIAGRAM

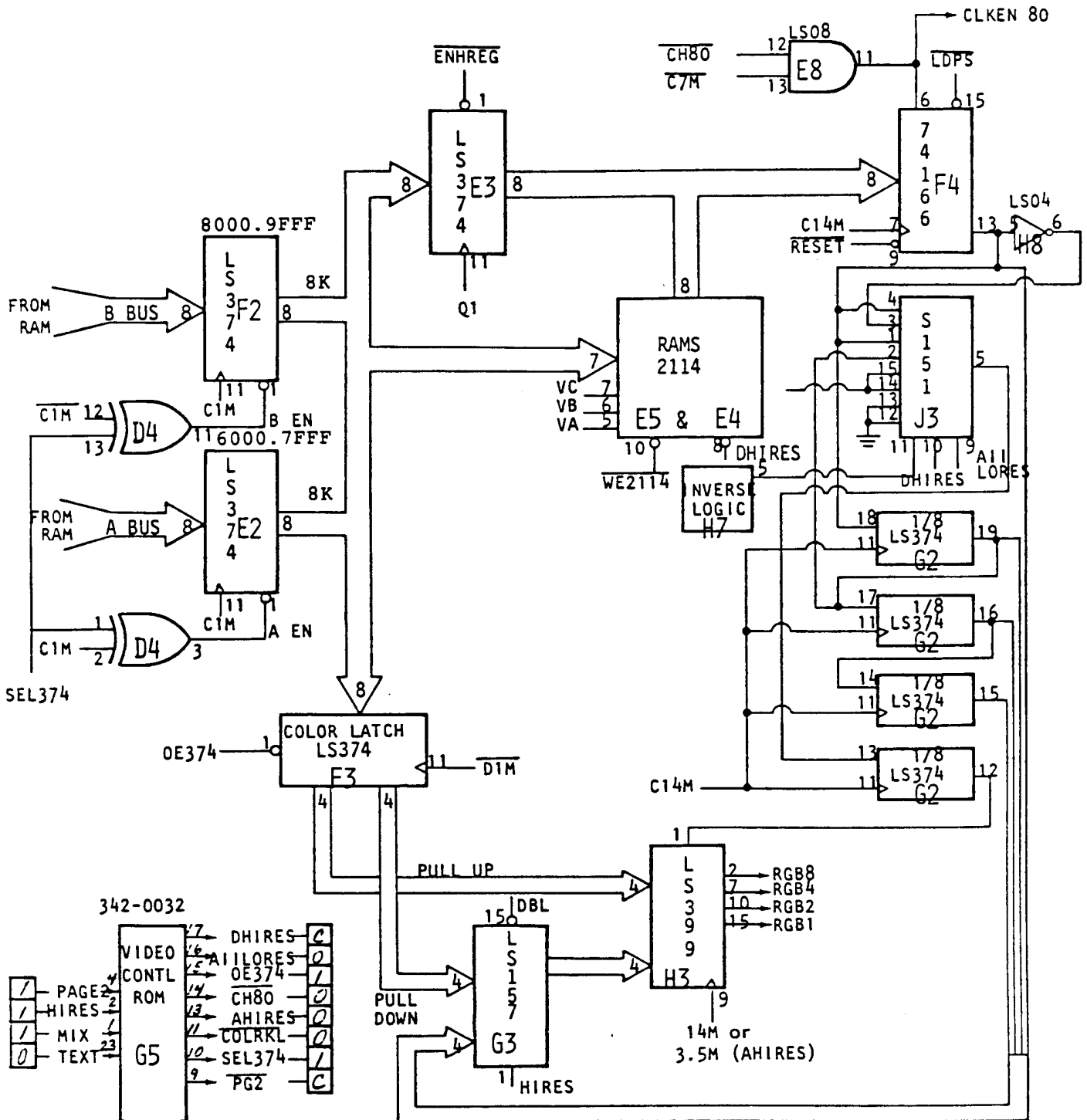

6. SUPER HIRES MODE PAGE 2 - B & W - 560 X 192  
6000.9FFF (16K)

A/// VIDEO LOGIC DIAGRAM

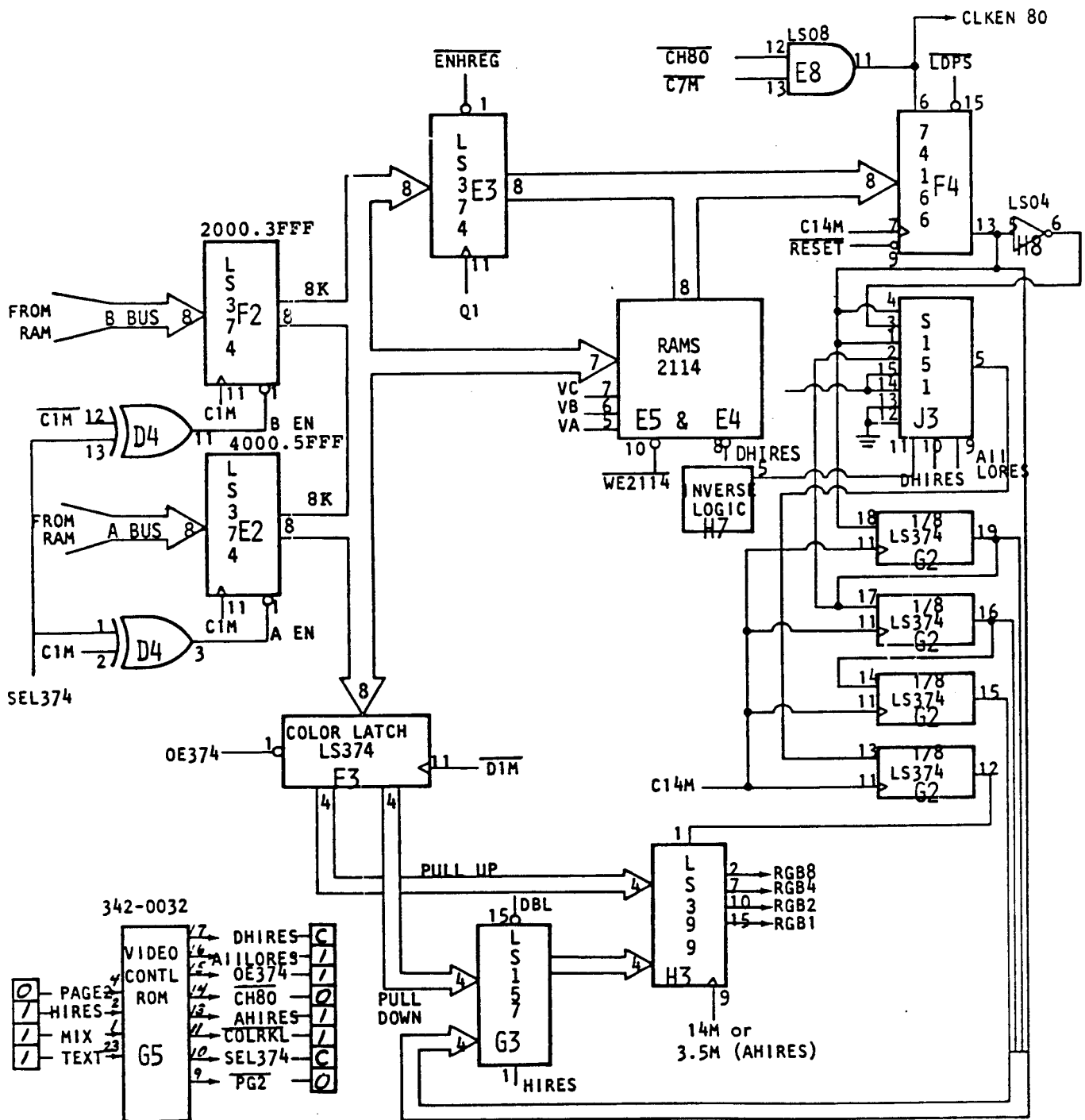

7. AHIREs TEST PAGE 1 - 140X192  
2000.5FFF (16K)

6.17

A/// VIDEO LOGIC DIAGRAM

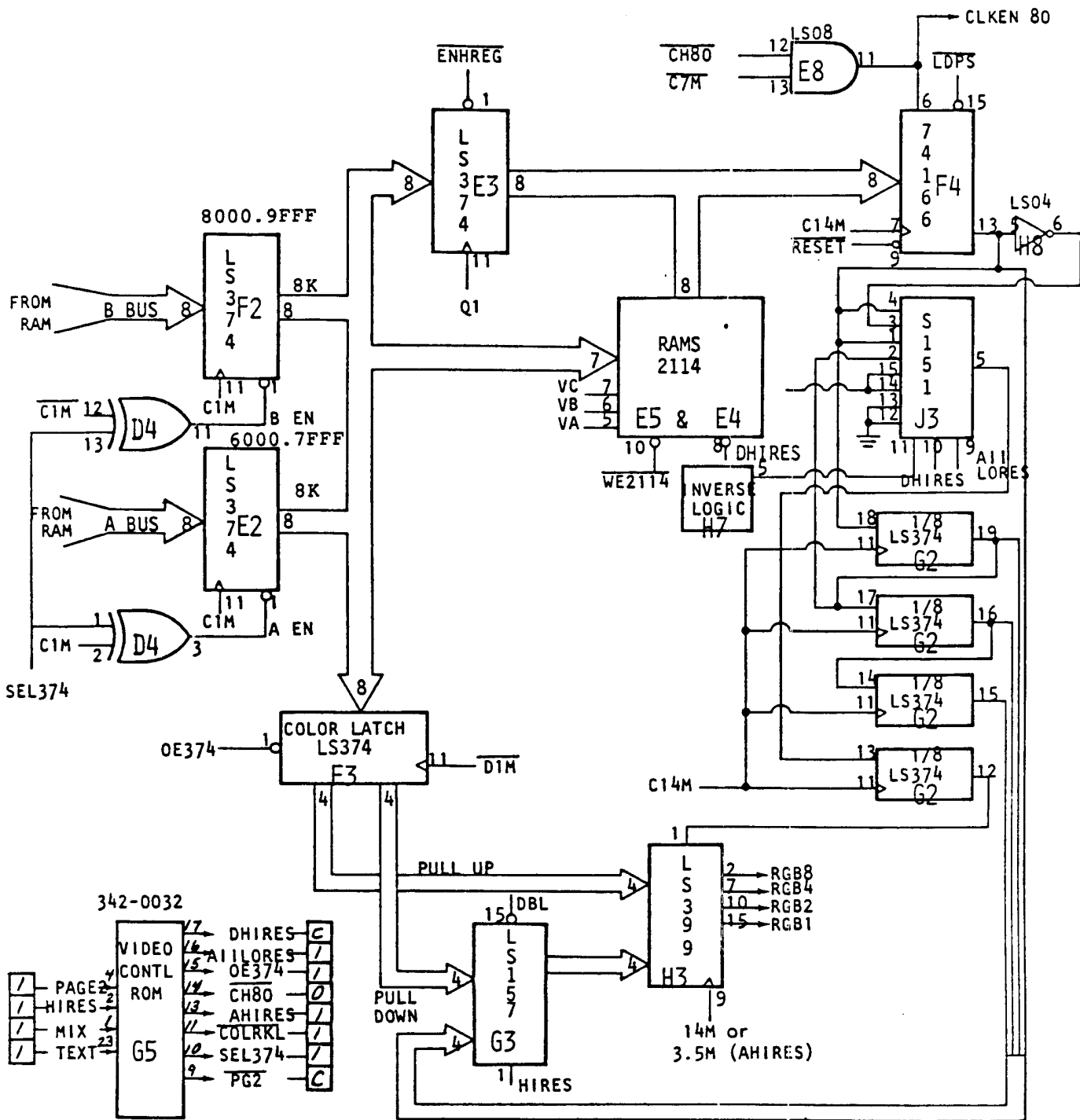

8. AHIRES TEST PAGE 2 - 140X192  
6000.9FFF (16K)

A/// VIDEO LOGIC DIAGRAM

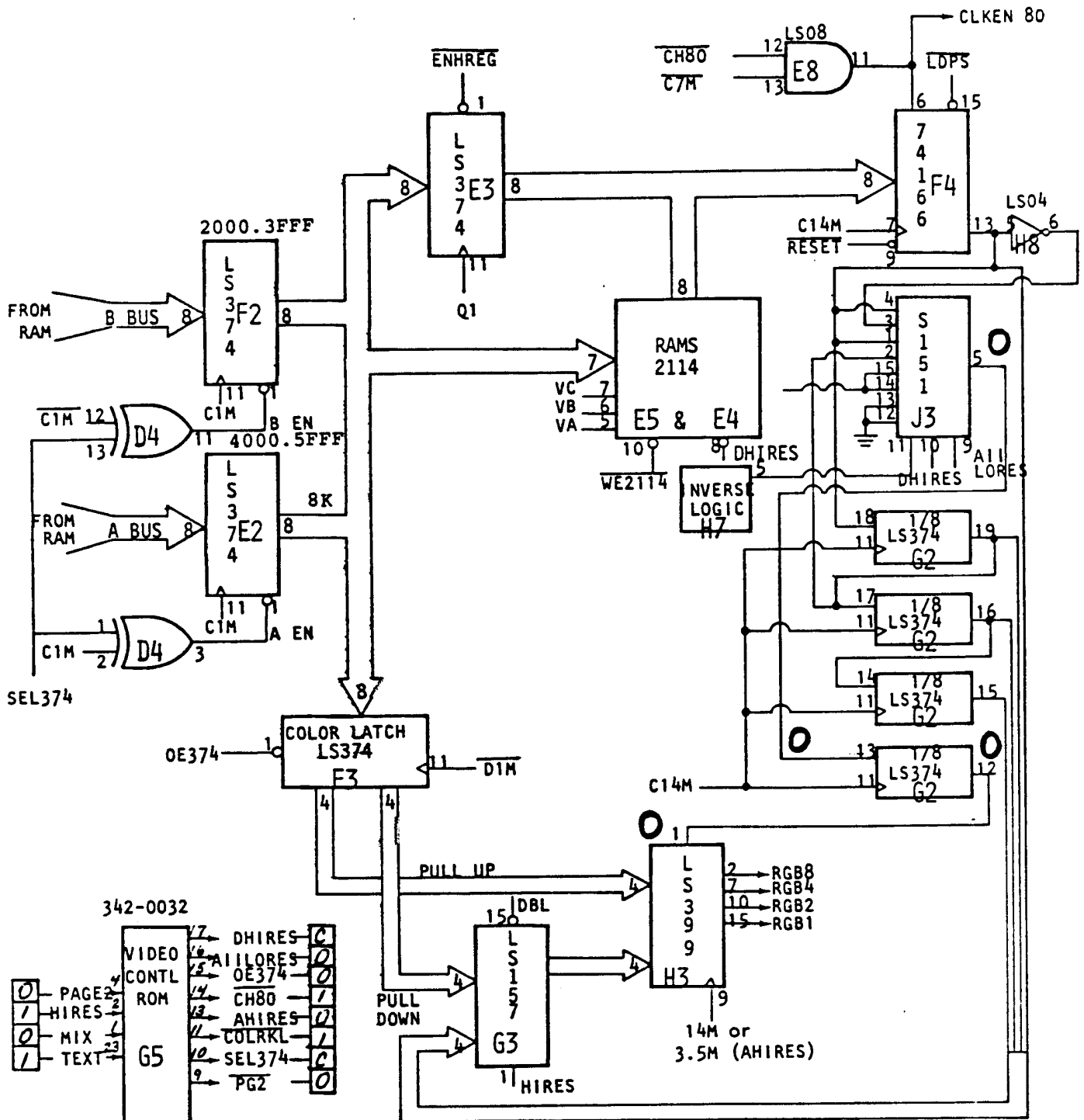

9. COLOR BAR & GRAY SCALE TEST  
2000.5FFF (16K)



### A/// VIDEO LOGIC DIAGRAM

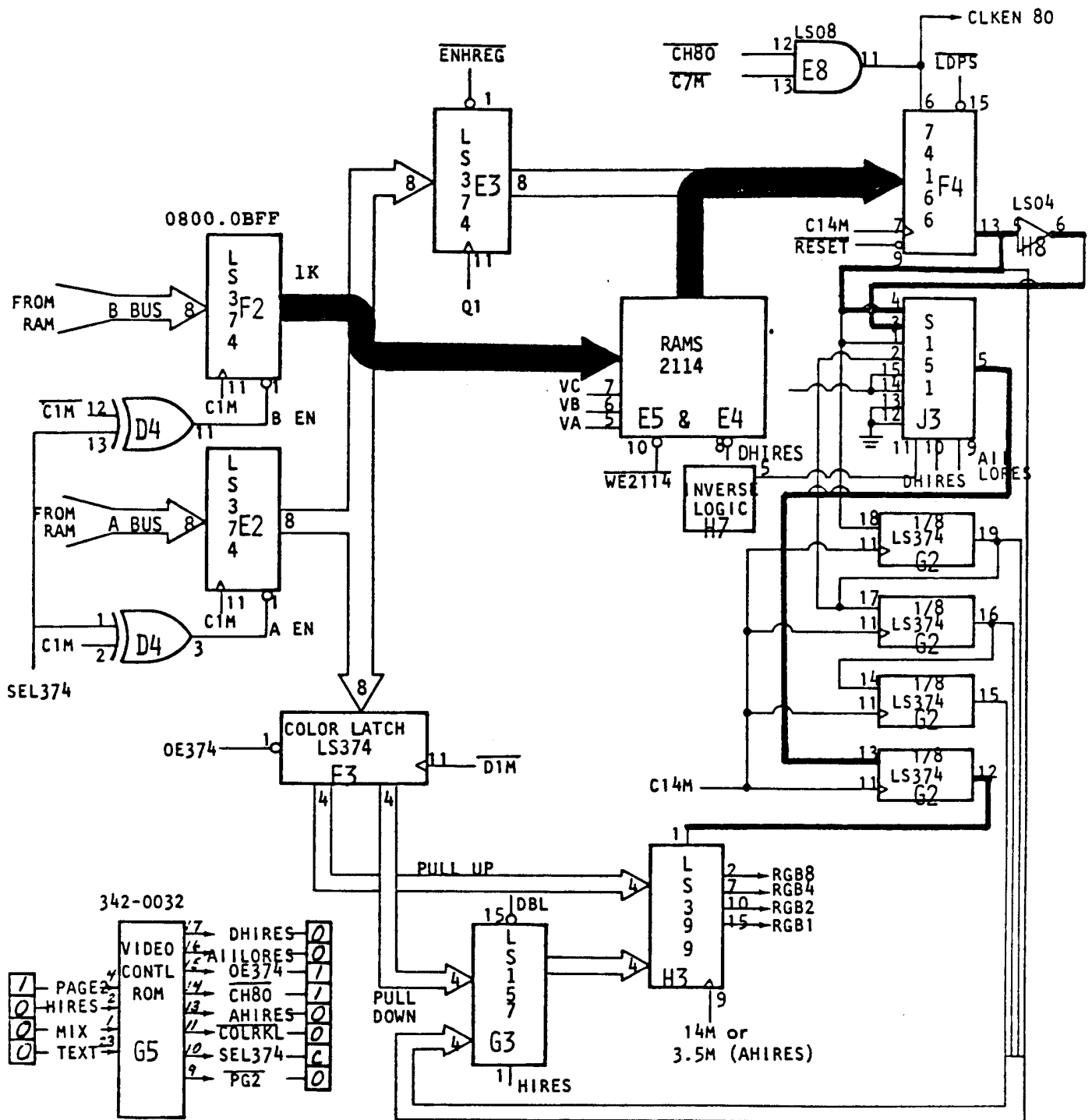

11. APPLE II TEST MODE PAGE 2 - B & W - 40 COLUMN  
0800-0BFF (1K)

A/// VIDEO LOGIC DIAGRAM

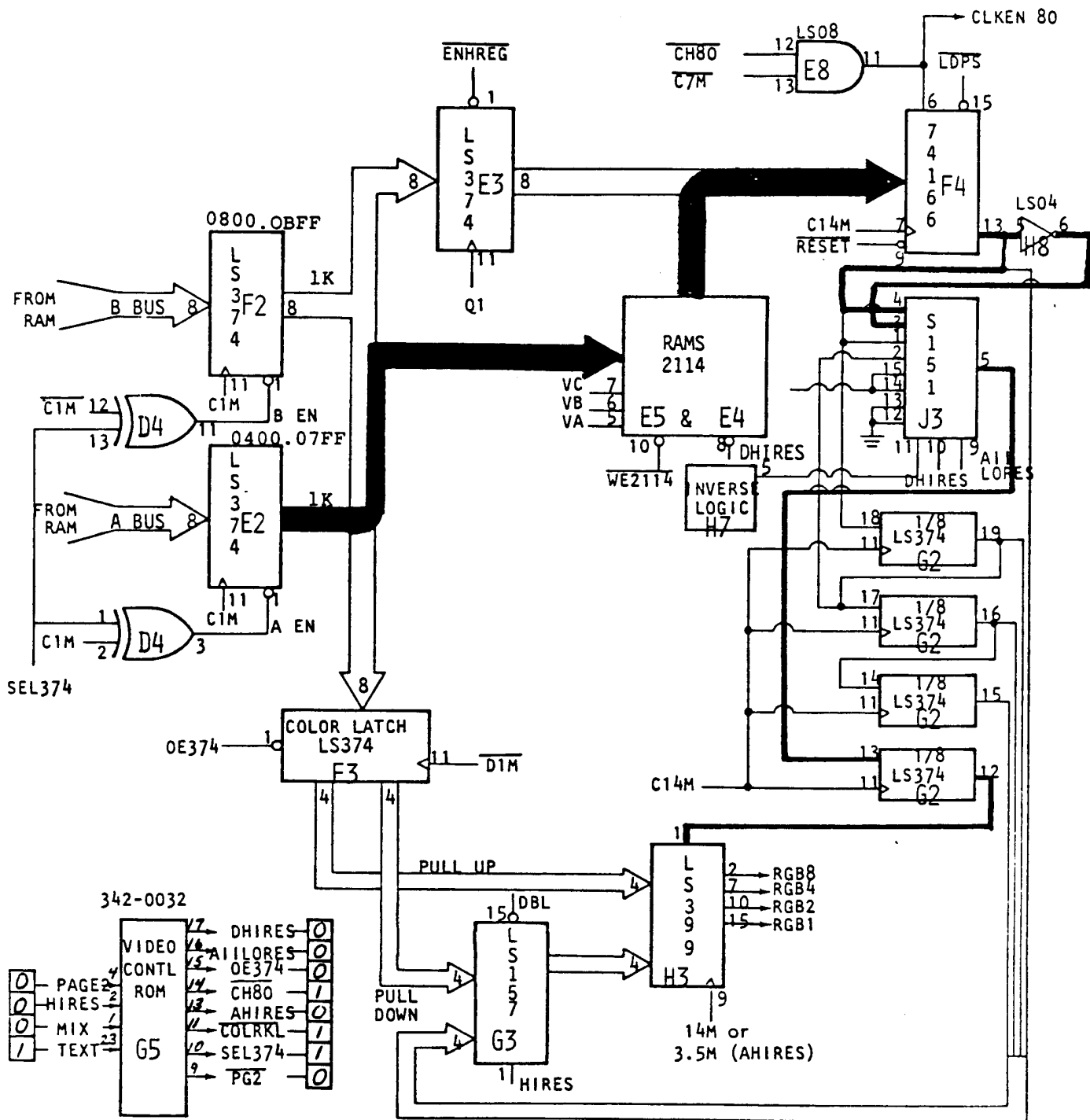

12. SARA 40 COLUMN TEXT MODE TEST- 16 COLORS  
0400.OBFF (2K)





# VIDEO MODES

## APPLE III

OUTPUTS  
ROM G5 (0032)  
INPUTS TO

Mode	Pin	ROM G5	ROM G5	ROM G5	ROM G5
H6 (9334)	pin 7	RDM pin 2	ROM pin 1	ROM pin 5	H6 (9334) pin 6
H6 (9334)	pin 5	ROM pin 1	ROM pin 1	ROM pin 5	H6 (9334) pin 4
H6 (9334)	pin 4	ROM pin 2	ROM pin 3	ROM pin 5	H6 (9334) pin 4
H6 (9334)	pin 6	ROM pin 4	ROM pin 4	ROM pin 5	H6 (9334) pin 6
4Ø CHAR AII (Ø/w)		Ø	Ø	Ø	Ø
4Ø CHAR SARA (color)		Ø	Ø	Ø	Ø
8Ø CHAR (Ø/w)		Ø	Ø	Ø	Ø
8Ø CHAR (Ø/w)		Ø	Ø	Ø	Ø
AII HIRES (250x192, B/W)		1	Ø	Ø	Ø
FGD/BKGD HIRES (280x192, 16 colors)		1	Ø	Ø	Ø
SUPER HIRES (560x192, B/W)		1	1	Ø	Ø
14Ø x 192 AHIRES (140x192, color)		1	1	1	Ø

### PAGE 1

OUTPUTS FROM ROM G5 (0032)

Mode	SEL 374	COLOR KL	A HIRES	CH 8Ø	OFF 374	A II LORES	Ø HIRES
4Ø CHAR AII (Ø/w)	G5 pin 9	G5 pin 11	G5 pin 13	G5 pin 14	G5 pin 15	G5 pin 16	G5 pin 17
4Ø CHAR SARA (color)	Ø	Ø	Ø	Ø	Ø	Ø	Ø
8Ø CHAR (Ø/w)	Ø	Ø	Ø	Ø	Ø	Ø	Ø
8Ø CHAR (Ø/w)	Ø	Ø	Ø	Ø	Ø	Ø	Ø
AII HIRES (250x192, B/W)	clocking	Ø	Ø	Ø	Ø	Ø	clocking
FGD/BKGD HIRES (280x192, 16 colors)	clocking	Ø	Ø	Ø	Ø	Ø	clocking
SUPER HIRES (560x192, B/W)	clocking	Ø	Ø	Ø	Ø	Ø	clocking
14Ø x 192 AHIRES (140x192, color)	clocking	Ø	Ø	Ø	Ø	Ø	clocking

### PAGE 2

Mode	SEL 374	COLOR KL	A HIRES	CH 8Ø	OFF 374	A II LORES	Ø HIRES
4Ø CHAR AII (Ø/w)	clocking	Ø	Ø	Ø	Ø	Ø	Ø
4Ø CHAR SARA (color)	clocking	Ø	Ø	Ø	Ø	Ø	Ø
8Ø CHAR (Ø/w)	clocking	Ø	Ø	Ø	Ø	Ø	Ø
8Ø CHAR (Ø/w)	clocking	Ø	Ø	Ø	Ø	Ø	Ø
AII HIRES (250x192, B/W)	Ø	Ø	Ø	Ø	Ø	Ø	clocking
FGD/BKGD HIRES (280x192, 16 colors)	Ø	Ø	Ø	Ø	Ø	Ø	clocking
SUPER HIRES (560x192, B/W)	Ø	Ø	Ø	Ø	Ø	Ø	clocking
14Ø x 192 AHIRES (140x192, color)	Ø	Ø	Ø	Ø	Ø	Ø	clocking

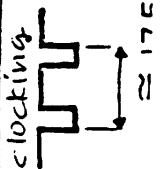





## VIDEO OUTPUTS

- o NTSC COLOR COMPOSITE VIDEO
- o NTSC B/W COMPOSITE VIDEO
- o SYNC
- o FOUR PRIMARY INDEPENDENT VIDEO LINES
- o MIX TO FORM RGB APPLE COLORS  
THREE LINES CAN DRIVE TTL RGB MONITOR

# VIDEO OUTPUTS

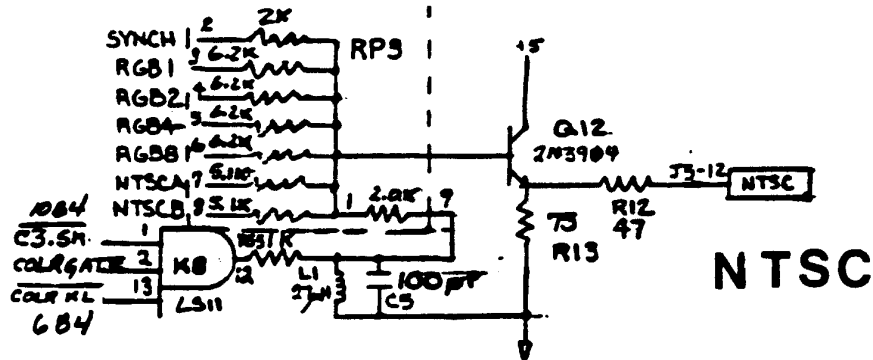

**NTSC**

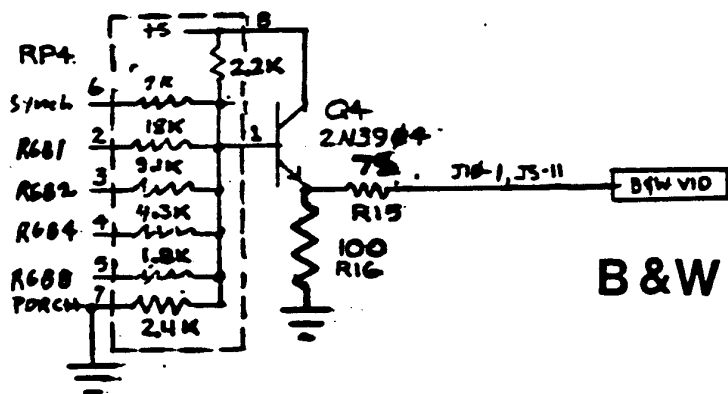

**B & W VIDEO**

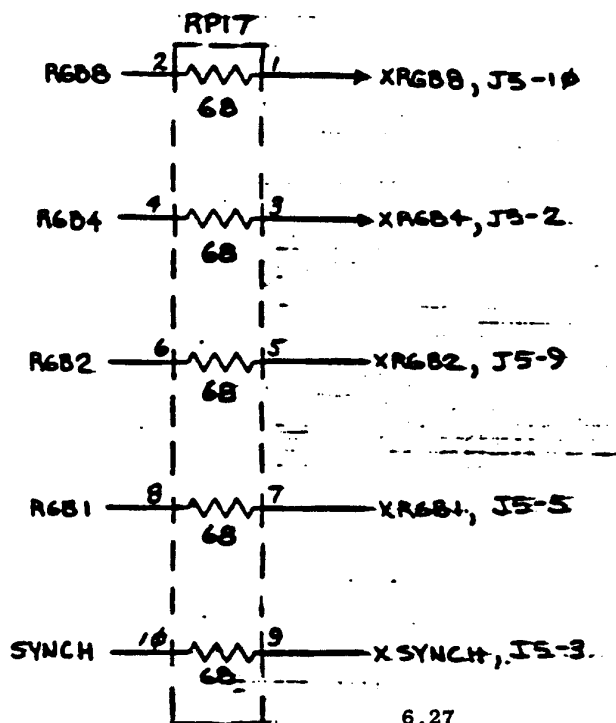

**RGB**

6.27

 **apple computer inc.**

6.28



ROM 341-0032

- A=A
- B=B
- C=S4
- D=VBL
- E=PAGE2
- F=AIISW'
- G=HIRES
- H=MIX
- I=TEXT
- J=V2
- K=V4
- DO=PG2
- D1=SEL374
- D2=COLRKL'
- D3=AHIRES
- D4=CH80'
- D5=OE374
- D6=AILORES
- D7=DHIRES

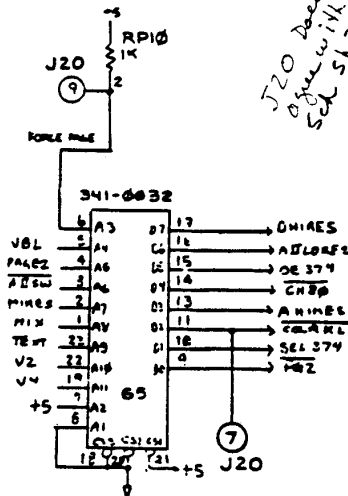

PG2=AIISW'\*(HIRES\*MIX'\*TEXT ')\*HIRES\*PAGE2\*S4\*VBL'

SEL374=(VBL'\*(AIISW\*(PAGE2'\*(TEXT +MIX\*V2\*V4)'+PAGE2\*(TEXT +MIX\*V2\*V4))+AIISW'\*(HIRES\*(PAGE2\*S4)'HIRES'\*(PAGE2\*S4))))'

COLRKL'=(AIISW\*TEXT +AIISW'\*(HIRES'\*(MIX+TEXT ')+HIRES\*TEXT '))'

AHIRES=AIISW'\*(HIRES\*MIX\*TEXT )

CH80'=(AIISW'\*MIX)'

OE374=(AIISW\*HIRES'\*(TEXT +MIX\*V2\*V4)'+AIISW'\*MIX'\*TEXT )'

AILORES=AIISW\*HIRES'\*(TEXT +MIX\*V2\*V4)'+AIISW'\*HIRES\*MIX\*TEXT

DHIRES=(AIISW\*HIRES\*(TEXT +MIX\*V2\*V4)'+AIISW'\*HIRES)\*VBL'

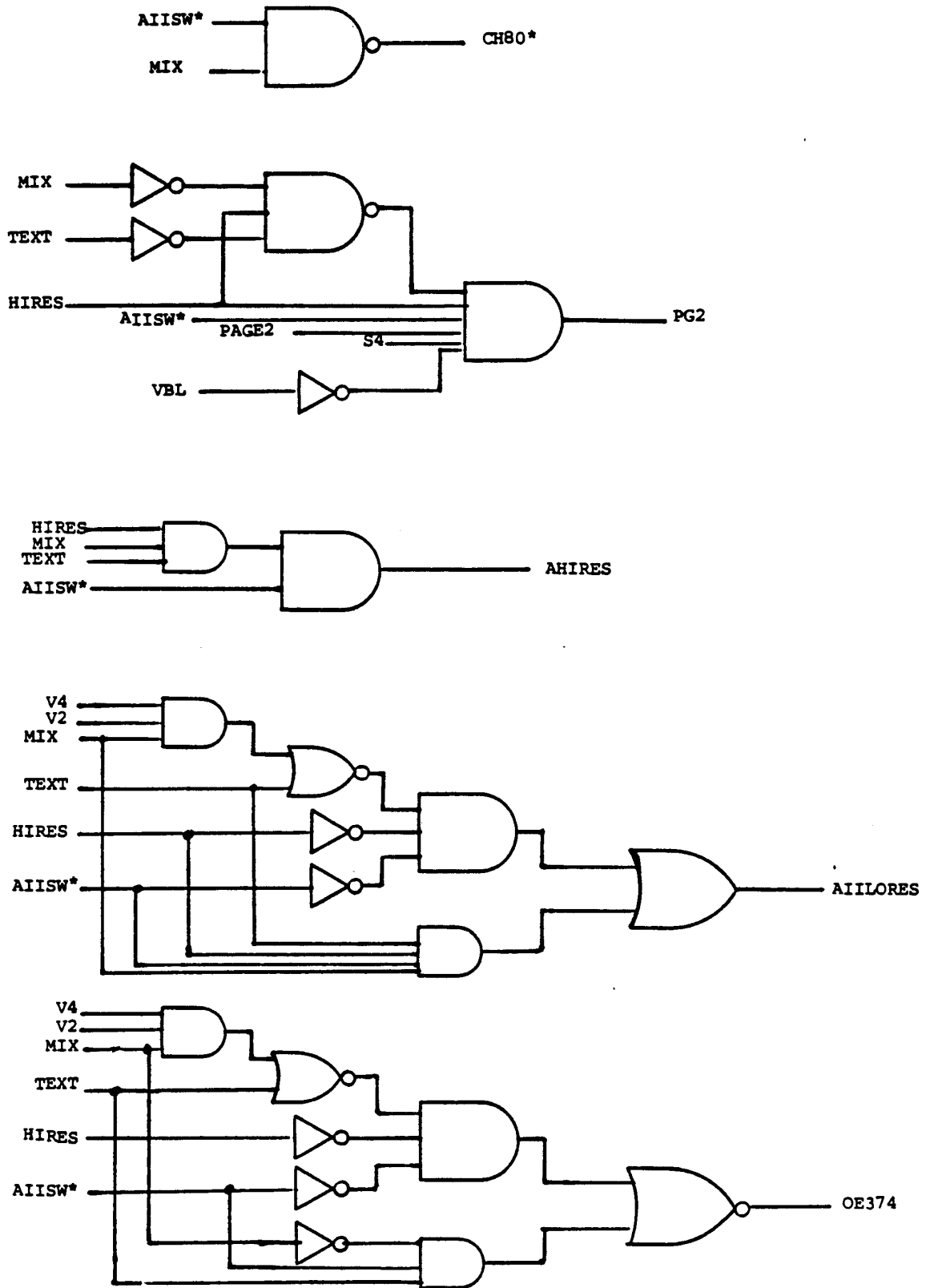

6.30



THE COLOR VIDEO CONNECTOR

<u>Pin</u>	<u>Name</u>	<u>Description</u>
1	SG	Shield Ground.
2	XRGB4	One of four GRB outputs. This (and pins 5, 9, and 10) is a TTL output with instantaneous color information. A linear weighted sum of these four signals will form a true 16-color RGB video signal.
3	SYNCH	Composite synchronization signal with negative-going tips.
4	PDI	Not used.
5	XRGB1	See pin 2.
6	GND	Power and signal ground.
7	-5V	-5 volt power supply. A device may draw up to 200 ma through this pin.
8	+12V	+12 volt power supply. A device may draw up to 500 ma through this pin.
9	XRGB2	See pin 2.
10	XRGB8	See pin 2.
11	BWVID	Black and white composite video. This is an NTSC composite video signal with negative-going synch tips, 1 volt peak-to-peak into a 75 ohm load. Color information is encoded as a linear grey scale.
12	NTSC	Color composite video. This is an NTSC-compatible video signal with negative-going synch tips, 1 volt peak-to-peak into a 75 ohm load.
13	GND	Power and signal ground.
14	-12V	-12 volt power supply. A device may draw up to 200 ma through this pin.
15	+5V	+5 volt supply. A device may draw up to 1 amp through this pin.

This connector supplies 7 different video signals and 4 power supply voltages. Through this connector you can hook up the Apple to any NTSC color or black and white video monitor. With an additional circuit you can hook up the Apple to a studio-quality RGB color monitor.

All power supply current ratings assume that no peripheral cards are installed in the system. If there are cards in the system, be sure to account for the current drawn by those cards.