

# **HDDD A2 v1.2**

## *User's Manual*

© 2009 bootZero

Rev. B

# Contents

<b>1</b>	<b>Introduction</b>	<b>4</b>
1.1	About HDDD A2 . . . . .	4
1.2	Features . . . . .	5
1.3	System Requirements . . . . .	5
<b>2</b>	<b>Installation</b>	<b>6</b>
2.1	Caution . . . . .	6
2.2	General Connection Scheme . . . . .	6
2.3	Connecting the Cables to HDDD A2 . . . . .	6
2.4	Attaching HDDD A2 to 3.5" HD Floppy Drive . . . . .	8
2.5	Connecting to Apple IIe . . . . .	9
2.6	Connecting to Apple IIc / IIc+ . . . . .	10
2.7	Connecting to Apple IIgs . . . . .	11
<b>3</b>	<b>Usage</b>	<b>12</b>
3.1	Side Selection . . . . .	12
3.2	Software . . . . .	12
3.3	Daisy Chain . . . . .	12
<b>4</b>	<b>For Advanced Users</b>	<b>13</b>
4.1	Conversion . . . . .	13
4.2	Extras . . . . .	13
4.3	Enhancements . . . . .	13
4.4	Deviations from Disk II . . . . .	14
4.4.1	Quarter Tracks . . . . .	14
4.4.2	Drive Speed . . . . .	14
4.4.3	Long Strings of Zeroes . . . . .	14
4.4.4	Protected Software . . . . .	15

# List of Figures

2.1	General Connection Diagram . . . . .	7
2.2	HDDD A2 Pinout . . . . .	7
2.3	IBM PC 3.5" HD Floppy Drive Pinout . . . . .	8
2.4	HDDD A2 Assembly . . . . .	8
2.5	Apple IIe with IDC-20 . . . . .	9
2.6	Apple IIe with DB19 . . . . .	9
2.7	Apple IIc Disk Port . . . . .	10
2.8	Apple IIc Connection . . . . .	10
2.9	Apple IIgs Disk Port . . . . .	11
2.10	Apple IIgs Connection . . . . .	11
4.1	External Switch . . . . .	14

# Chapter 1

## Introduction

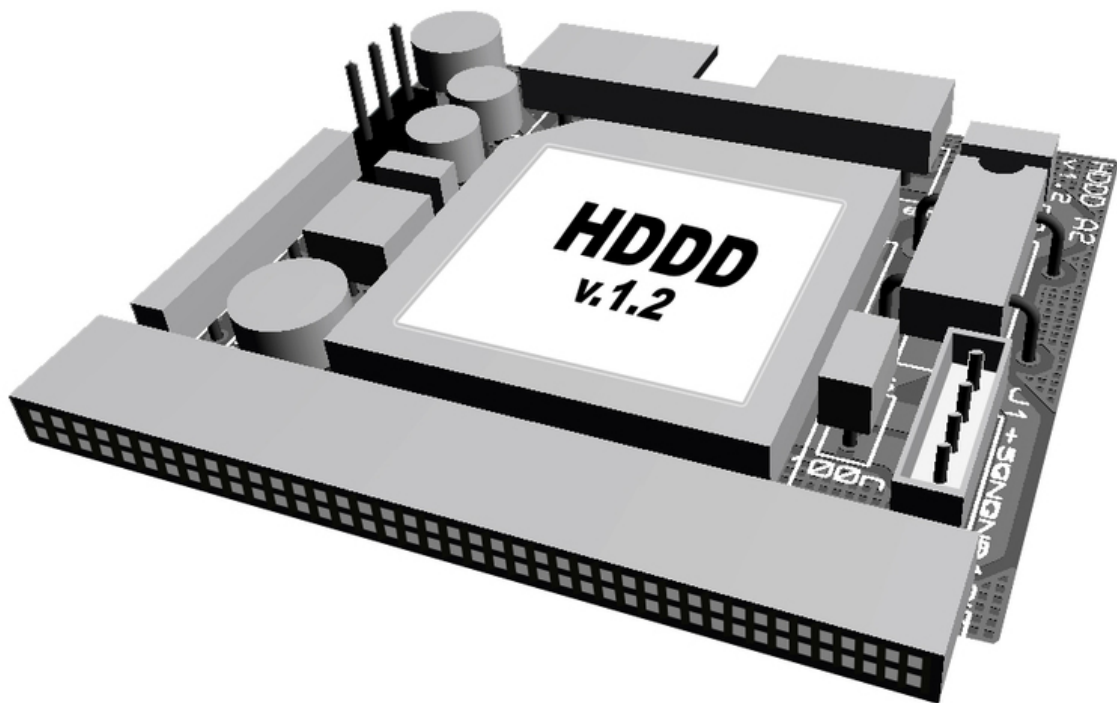

### 1.1 About HDDD A2

HDDD A2 is a modern product for the Apple II family of computers. While the Apple II computers haven't lost their charm even after few decades, their 5.25" drives and diskettes are beginning to show the signs of age and wear and getting scarce. HDDD A2 tries to fill this gap and still keep the retro feeling by making a standard IBM PC 3.5" HD floppy drive and 3.5" HD diskettes a direct replacement of the venerable Disk II drive.

## 1.2 Features

- mimicking of Disk II drive
- user-selectable side
- 80 tracks per side
- 140 KB per side compatible with DOS 3.3, ProDOS, UCSD, CP/M
- up-to 320 KB per side (no software supplied)

## 1.3 System Requirements

- Apple II computer with Disk II controller card in a slot or integrated disk port
- IBM PC 3.5" HD floppy drive
- 3.5" HD diskettes

Please note that HDDD A2 board doesn't support neither 3.5" DD drives nor 3.5" DD diskettes.

# Chapter 2

## Installation

### 2.1 Caution

Please be sure to turn off your Apple II system before making any changes to the hardware or connections. Attempt to connect or disconnect components while system is powered will likely lead to damage.

Please check very carefully the markings on the ribbon cable connecting HDDD A2 and your Apple II computer before applying power to the system to avoid irreversible damage.

### 2.2 General Connection Scheme

HDDD A2 board has the following connectors (Figure 2.1):

**F1:** 34way socket, to 3.5" HD floppy drive

**AP1:** 20way header, to Apple II

**J1:** 4way power header, to 3.5" HD floppy drive power supply

**JP1:** 3way header, jumper for side selection

### 2.3 Connecting the Cables to HDDD A2

To avoid excess force applied to the HDDD A2 board while already attached to the 3.5" HD floppy drive, we recommend that first the cables are installed.

Plug your selected ribbon cable (IDC-20 or DB19, depending on your Apple II model) in **AP1**.

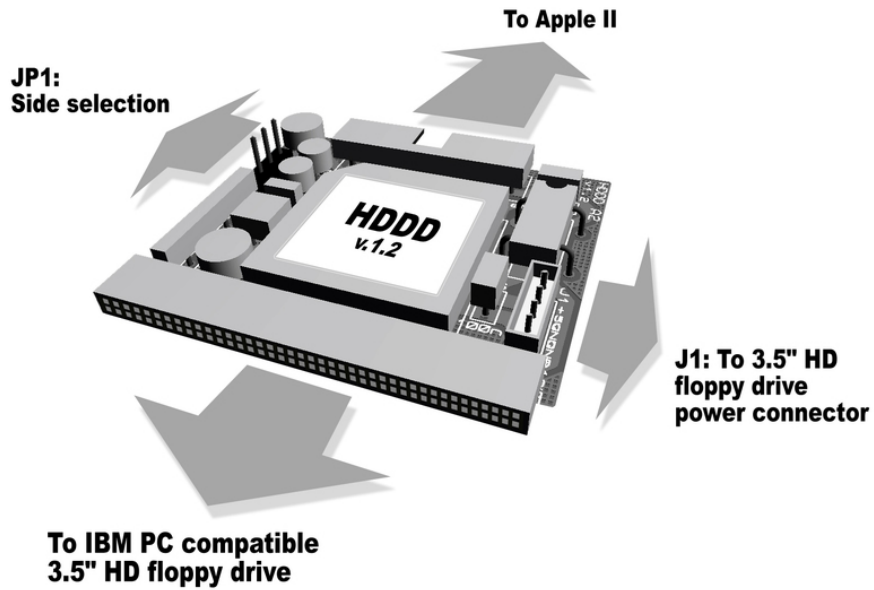

Figure 2.1: General Connection Diagram

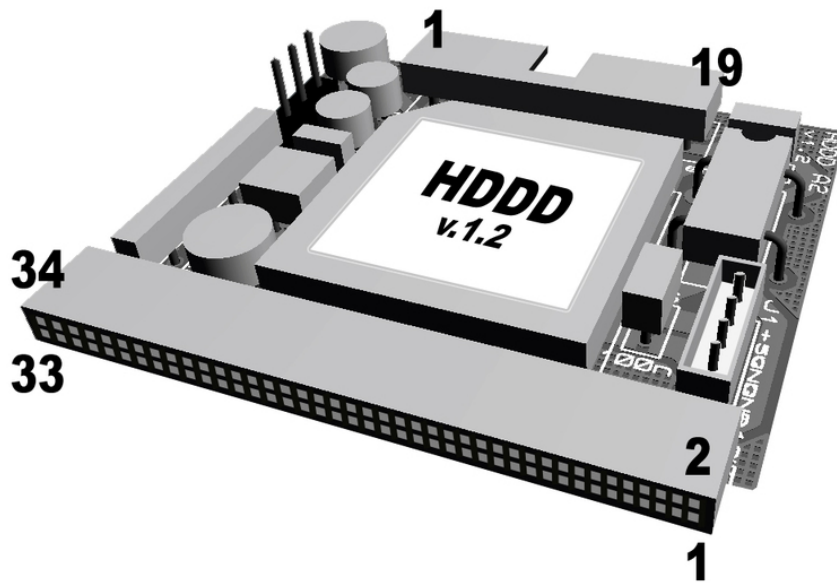

Figure 2.2: HDDD A2 Pinout

Plug the short 4-lead coloured power supply cable in **J1**. Alternatively, skip this step and leave **J1** empty if you plan to power the 3.5" HD floppy drive from external ATX power supply.

## 2.4 Attaching HDDD A2 to 3.5" HD Floppy Drive

Attach the HDDD A2 board's F1 socket to the 34way header at the rear side of the 3.5" HD floppy drive, matching pin numbers. Consult Figure 2.3 for general diagram of a 3.5" HD drive. Usually pin #3 is keyed. For the majority of the drives the HDDD A2 board will face components up.

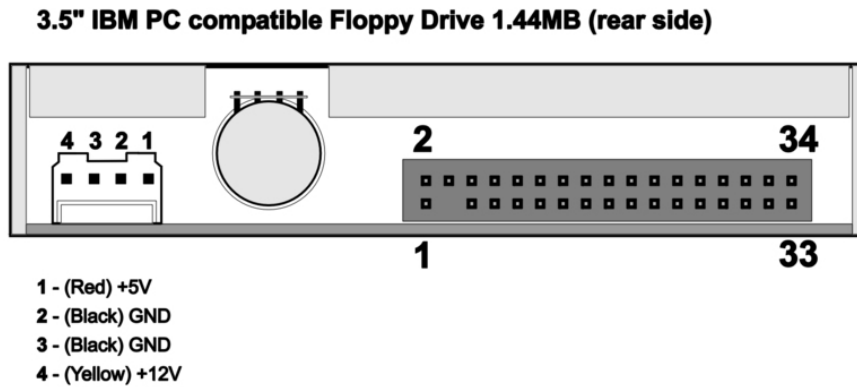

Figure 2.3: IBM PC 3.5" HD Floppy Drive Pinout

Plug the other end of the short 4-lead colored power supply cable in 3.5" HD floppy drive's 4-pin power supply header. Alternatively, connect external ATX power supply's floppy drive lead to the 3.5" HD floppy drive's 4-pin power supply header if your Apple II cannot deliver enough power for the floppy drive.

After these steps your assembly should look like Figure 2.4. Pay close attention to the red marking on the ribbon cable.



Figure 2.4: HDDD A2 Assembly



## 2.5 Connecting to Apple IIe

If your Apple IIe is using the standard disk controller card with two 2x10 headers, plug the other end of the ribbon cable to the selected drive number as shown in Figure 2.5. Pay close attention to the red marking on the ribbon cable.

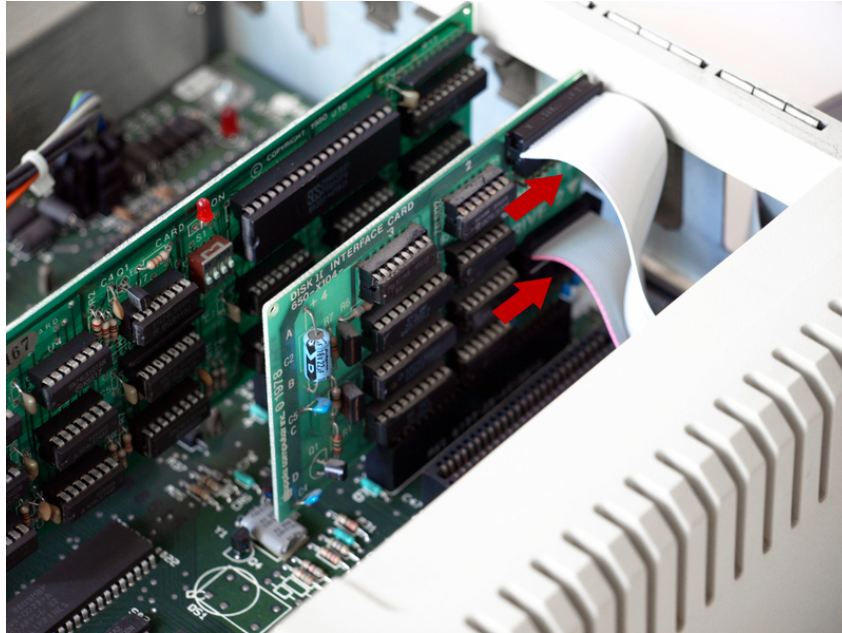

Figure 2.5: Apple IIe with IDC-20

If your Apple IIe has DB19 connector at it's rear panel, plug the other end of the ribbon cable to it as shown in Figure 2.6.



Figure 2.6: Apple IIe with DB19

## 2.6 Connecting to Apple IIc / IIc+

Find the DB19 disk port on the rear panel (Figure 2.7) and connect the other end of the ribbon cable to it as shown in Figure 2.8.



Figure 2.7: Apple IIc Disk Port



Figure 2.8: Apple IIc Connection

## 2.7 Connecting to Apple IIgs

Find the DB19 disk port on the rear panel (Figure 2.9) and connect the other end of the ribbon cable to it as shown in Figure 2.10.

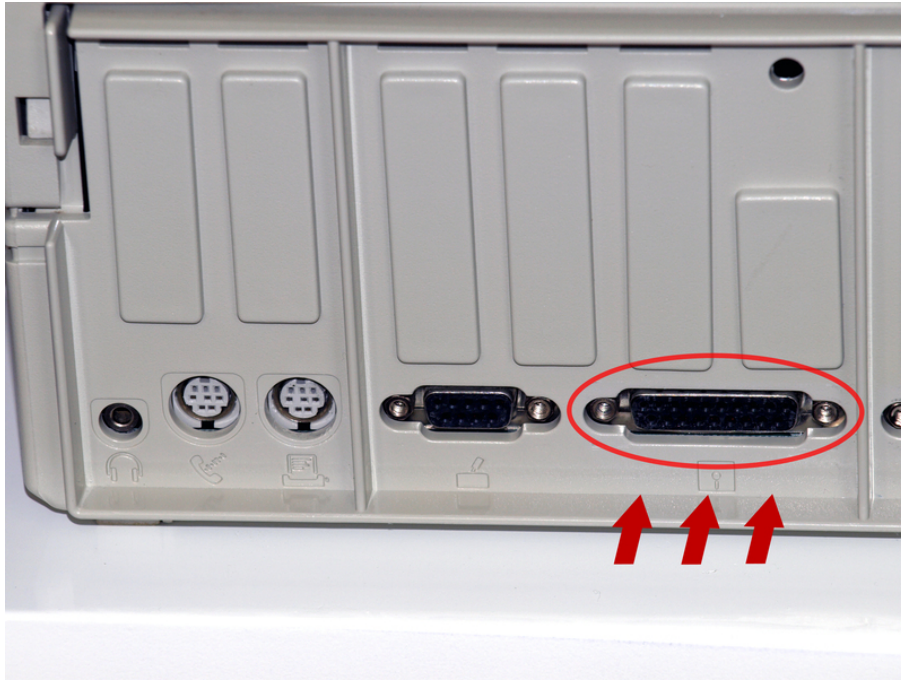

Figure 2.9: Apple IIgs Disk Port



Figure 2.10: Apple IIgs Connection

# Chapter 3

## Usage

### 3.1 Side Selection

Disk II supports only single side and there is no electrical signal or notion for side selection, so this has to be selected manually. HDDD A2 provides 3way header **JP1** with jumper for side selection. Two LEDs on the board indicate currently selected side. Please do not change side while write operation is in progress, as this may result in data loss. For increased flexibility you may install external switch and indication at a convenient place.

### 3.2 Software

There is nothing special to do to use HDDD A2 in place of Disk II. After successful installation you can start using 3.5" HD diskettes the same way as the old 5.25" DD ones - format and copy using your favourite software and enjoy. Please keep in mind that 3.5" HD diskettes cannot be flipped upside-down - use the side selection jumper to achieve this.

### 3.3 Daisy Chain

Please note that HDDD A2 doesn't directly allow connecting a daisy-chained drive after itself, as it lacks a physical pass-through port. One possible solution is bootZero's *A2split*, an external splitter/addon, which allows various combinations of daisy-chained and non daisy-chained drives and even two HDDD A2.

# Chapter 4

## For Advanced Users

### 4.1 Conversion

The original Disk II is a double density (DD), 300 RPM device. Double density corresponds to 250 kbit/sec transfer rate. Apple II computers use a form of Group Code Recording (GCR) encoding invented by Steve Wozniak and their diskettes are incompatible with other platforms.

3.5" high density (HD) drives work also at 300 RPM, but at an increased transfer rate of 500 kbit/sec. Of course the increased capacity per track cannot be used and at the same time still be compatible with Apple II disk controllers and software, so HDDD A2 employs additional FM encoding on top of the Apple's GCR to satisfy magnetic media requirements.

HDDD A2 also does the necessary signal conversions between Apple II and IBM PC compatibles' floppy drives.

Each "half" track of Disk II is mapped to a separate track on the 3.5" HD diskette. Thus any standard Apple II operating system such as DOS 3.3, ProDOS, CP/M and UCSD will actually use only every other track on the 3.5" HD diskette.

### 4.2 Extras

While half of each track is sacrificed in the name of compatibility, there is still benefit - increased number of tracks. There are 80 of them on each side, leading to theoretical capacity of 320 KB per side assuming standard 16-sector format.

### 4.3 Enhancements

For users who need to switch sides often we recommend connecting an external single pole double throw (SPDT) switch to **JP1** header and mounting it at a convenient place. Figure 4.1 shows sample electrical diagram.

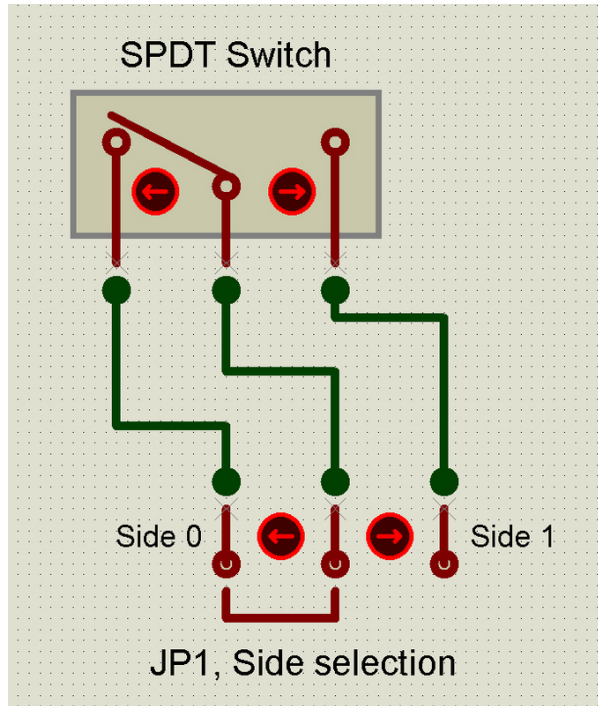

Figure 4.1: External Switch

## 4.4 Deviations from Disk II

Because the drive, the media and the signal encoding are different, there are minor observed differences.

### 4.4.1 Quarter Tracks

There are no “quarter” tracks with HDDD A2. They are mapped to the nearby “half” track depending on head movement direction. Software trying to utilise them will likely fail.

### 4.4.2 Drive Speed

3.5” HD drive’s speed is fixed internally at 300 RPM, while Disk II is usually calibrated at a slightly lower speed for optimum performance. This shortens the effective track length of HDDD A2 by a negligible amount compared to a calibrated Disk II spinning at sub-300 RPM.

### 4.4.3 Long Strings of Zeroes

Long strings of zeroes written to Disk II will result in random data being read back because of lost synchronisation and other peculiar effects in the floppy drive’s electronics. HDDD A2 uses additional FM encoding and will read back the data exactly as it was written.

#### **4.4.4 Protected Software**

Last but not least - even if these differences (especially the lack of “quarter” tracks) may affect some complex copy-protected titles, for the majority it should be possible to be transferred to 3.5” HD diskettes by HDDD A2 for backup or everyday usage.

## Contacts

Product updates and general information:

<http://www.bootzero.com>

Support:

[support@bootzero.com](mailto:support@bootzero.com)

Sales:

[sales@bootzero.com](mailto:sales@bootzero.com)

## Revision History

2009-12-28	(Rev. B) separated Errata
2009-09-05	(Rev. A) initial creation